

NOTES:

1. TEMPERATURE OF PIPE MUST NOT EXCEED 120° F (49° C).
2. APPLY TPO PRIMER TO THE TPO MEMBRANE AND PENETRATION(S) SURFACES ONLY. DO NOT APPLY TPO PRIMER TO THE GALVANIZED METAL SURFACE ON THE INSIDE OF THE SEALANT POCKET.
3. FILL POCKET COMPLETELY WITH THERMOPLASTIC ONE-PART SEALANT UNTIL RIM IS COVERED WITH SEALANT; ENSURE ALL VOIDS ARE FILLED.
4. SEALANT POCKET TO BE MINIMUM 1" (25 mm) FROM PENETRATION ON ANY SIDE.
5. ON MECHANICALLY-ATTACHED SYSTEMS, INSTALL A MINIMUM OF 4 FASTENING PLATES AROUND SEALANT POCKETS WITH A DIAMETER UP TO 6" (150 mm). ADDITIONAL FASTENING PLATES WILL BE REQUIRED FOR SEALANT POCKETS GREATER THAN 6" IN DIAMETER AND SHALL BE SPACED 12" (300 mm) ON CENTER MAXIMUM. FASTENERS/PLATES ARE NOT REQUIRED ON ADHERED SYSTEMS UNLESS SEALANT POCKET DIAMETER EXCEEDS 12" (300 mm).
6. REFER TO "ATTACHMENT I, MEMBRANE FASTENING CRITERIA" FOR PROPER FASTENERS AND PLATES.
7. APPROXIMATELY 1/8" (3 mm) DIAMETER BEAD OF CUT-EDGE SEALANT IS REQUIRED ON CUT EDGES OF REINFORCED MEMBRANE.

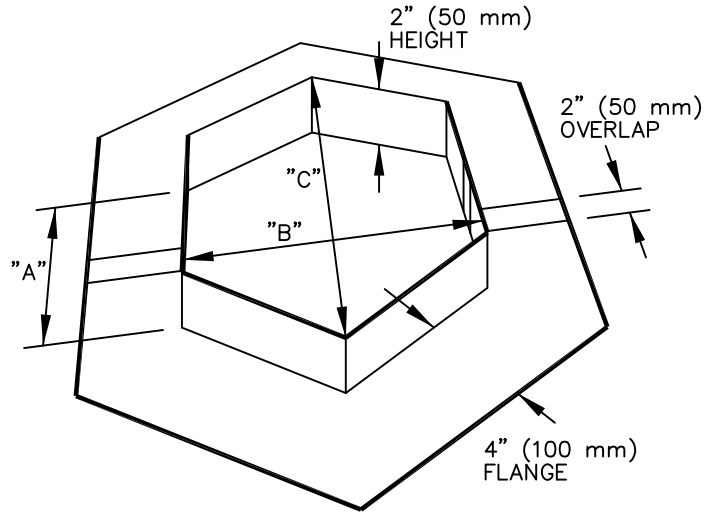

POCKET SIZE	DIMENSIONS		
	"A"	"B"	"C"
12" (300 mm)	12" (300 mm)	12" (300 mm)	24" (600 mm)
16" (400 mm)	12" (300 mm)	16" (400 mm)	28" (710 mm)
20" (500 mm)	12" (300 mm)	20" (500 mm)	32" (810 mm)

SEALANT POCKET EXTENSION LEGS CAN BE USED TO EXTEND THE LENGTH IN 10" (150 mm) INCREMENTS.

TPO PRE-FABRIACTED SEALANT POCKET

