

NOTES:

1. TEMPERATURE OF PIPE MUST NOT EXCEED 120° F (49° C).
2. TPO PRIMER MUST BE APPLIED TO ALL INSIDE SURFACES AND PENETRATIONS PRIOR TO FILLING WITH SEALANT.
3. FILL POCKET COMPLETELY WITH THERMOPLASTIC ONE-PART SEALANT UNTIL RIM IS COVERED WITH SEALANT; ENSURE ALL VOIDS ARE FILLED.
4. SEALANT POCKET TO BE MINIMUM 1" (25 mm) FROM PENETRATION ON ANY SIDE.
5. ON MECHANICALLY-ATTACHED SYSTEMS, INSTALL A MINIMUM OF 4 FASTENING PLATES AROUND SEALANT POCKETS WITH A DIAMETER UP TO 6" (150 mm). ADDITIONAL FASTENING PLATES WILL BE REQUIRED FOR SEALANT POCKETS GREATER THAN 6" IN DIAMETER AND SHALL BE SPACED 12" (300 mm) ON CENTER MAXIMUM. FASTENERS/PLATES ARE NOT REQUIRED ON ADHERED SYSTEMS UNLESS SEALANT POCKET DIAMETER EXCEEDS 12" (300 mm).
6. REFER TO "ATTACHMENT I, MEMBRANE FASTENING CRITERIA" FOR PROPER FASTENERS AND PLATES.
7. APPROXIMATELY 1/8" (3 mm) DIAMETER BEAD OF CUT-EDGE SEALANT IS REQUIRED ON CUT EDGES OF REINFORCED MEMBRANE.

PLACE MOLDED TPO SEALANT POCKET AROUND PENETRATION AND OVERLAP THE TWO SECTIONS

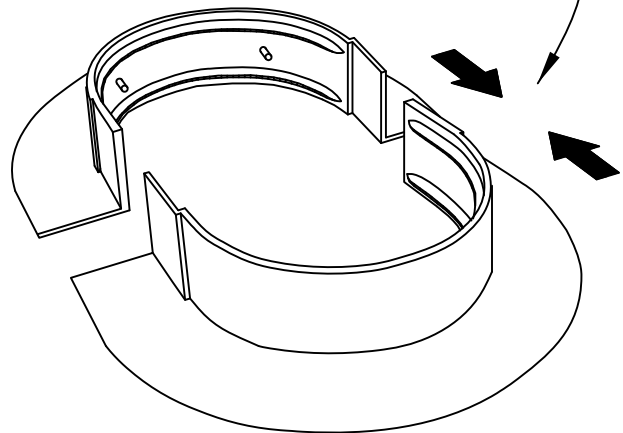

SIZE: 7.5" x 6" OVAL (190 mm x 150 mm)

MOLDED TPO SEALANT POCKET

